

Connection plan pcb armchair-V2

21.08.2023

gpio19: driver box
ds18b20 temp sensors
(drivers, motors)

gpio21: FREE

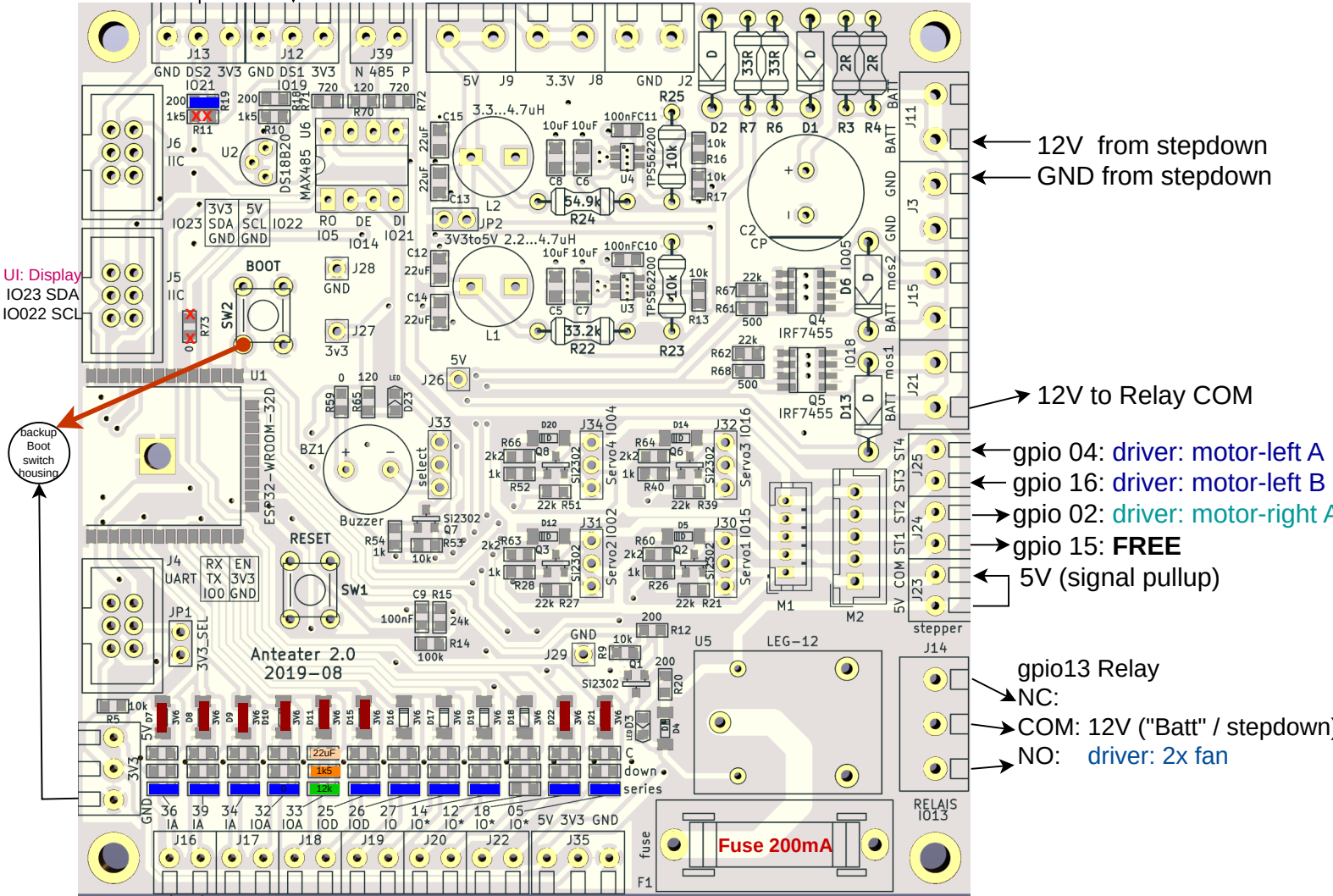

- ← 12V from stepdown
- ← GND from stepdown
- 12V to Relay COM
- ← gpio 04: driver: motor-left A
- ← gpio 16: driver: motor-left B
- gpio 02: driver: motor-right A
- gpio 15: FREE
- ← 5V (signal pullup)
- gpio13 Relay
- NC:
- COM: 12V ("Batt" / stepdown)
- NO: driver: 2x fan

UI: Display
IO23 SDA
IO22 SCL

Backup
Boot
switch
housing

- ← gpio 36: ADC UI: Joystick Y
- ← gpio 39: ADC UI: Joystick X
- ← gpio 34: ADC driver: Current sensor motor-left
- ← gpio 32: ADC driver: Current sensor motor-right
- ← gpio 33: ADC Battery voltage (stepdown) [29.4 -> 3.27V]
- ← gpio 25: UI: encoder switch
- ← gpio 26: driver: motor-left PWM
- ← gpio 27: driver: motor-right PWM
- ← gpio 14: [RS485] driver: motor-right B
- ← gpio 12: [LED/BUZZER]
- ← gpio 18: [MOS1] UI: encoder B
- ← gpio 05: [MOS2] UI: encoder A

Legend pcb

- 0 Ohm Resistor
- 1.5k Ohm Resistor
- 3v3 Z-Diode
- 12k Ohm Resistor
- 1k5 Ohm Resistor

[xxx] Conflicting Component
xx nopop

cable configuration	
<p style="text-align: center; color: blue;">control-box => driver-box</p> <p>Oelflex 12x0.5</p> <p>gn: GND 01: 5V 01: 3V3</p> <p>02: bridge-left A 03: bridge-left B 04: bridge-left PWM</p> <p>05: bridge-right A 06: bridge-right B 07: bridge-right PWM</p> <p>08: current-sensor left 09: current-sensor right</p> <p>10: fan 12v from relay 11: ds18b20 owb</p>	<p style="text-align: center; color: magenta;">control-box => UI-arm</p> <p>D-Sub 9 pin</p> <p>green: GND red: 3V3</p> <p>brown: Joystick X purple: Joystick Y</p> <p>yellow: encoder A blue: encoder B black: encoder switch</p> <p>gray: display SDA orange: display SDC</p> <div style="border: 1px solid black; padding: 5px; margin-top: 10px;"> <p style="text-align: center;">Joystick pinout</p> <p>JST connector 5 pin (pins stick order left to right)</p> <p>red: VCC (3V3) orange: GND brown: X (analog 0-3V) white: n.c. black: Y (analog 0-3V)</p> </div>

Wiring-plan

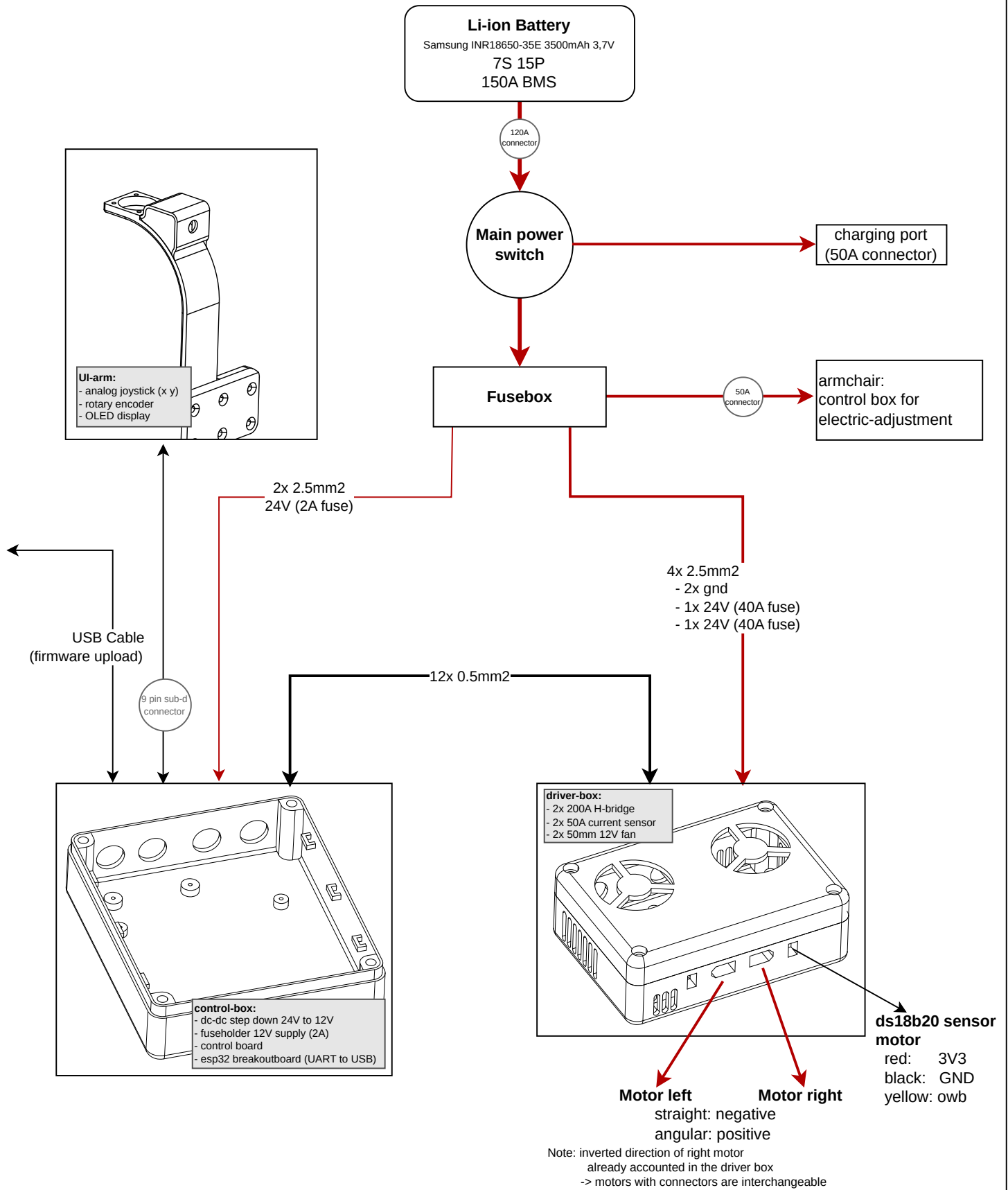

Driver overview

